

300mA, Low Power, Low Dropout, RF-Linear Regulators

General Description

The SWLD2336 series low-power, low-noise, low-dropout, CMOS linear voltage regulators operate from a 1.6V to 5.5V input voltage and deliver up to 300mA output current. They are the perfect choice for low voltage, low power applications. A low ground current makes this part attractive for battery operated power systems. The SWLD2336 series also offer low dropout voltage to prolong battery life in portable electronics. Systems requiring a quiet voltage source, such as RF applications, will benefit from the SWLD2336 series' low output noise and high PSRR.

Other features include a 10nA logic-controlled shutdown mode, short current limit and thermal shutdown protection.

The SWLD2336 has auto-discharge function to quickly discharge V_{OUT} in the disable status.

The SWLD2336 is available in Green UTDFN-1X1-4L, SOT-23-5 and SC70-5 packages.

It operates over an ambient temperature range of -40°C to $+85^{\circ}\text{C}$.

Features

- Low Dropout Voltage
- Thermal-Overload Protection
- Built-In Fold Back Protection Circuit
- 20uA Low Supply Current
- 10nA Logic-Controlled Shutdown
- 1.6V to 5.5V Input Voltage Range
- Fixed Outputs of 0.8V, 0.9V, 1.0V, 1.05V, 1.1V, 1.2V, 1.3V, 1.35V, 1.5V, 1.8V, 1.85V, 2.1V, 2.2V, 2.3V, 2.5V, 2.6V, 2.7V, 2.8V, 2.85V, 2.9V, 3.0V, 3.1V, 3.3V, 3.6V, 4.2V, 4.4V and 5.0V
- Adjustable Output from 0.8V to 5.0V
- Short Auto-Discharge Function
- 300mA Output Current
- High Output Voltage Accuracy
- Quick Start-Up Time
- Operating Temperature Range: -40°C to $+85^{\circ}\text{C}$

Applications

- Cellular Telephones
- Cordless Telephones
- PCMCIA Cards
- Modems and MP3 Player
- Hand-Held Instruments
- Palmtop Computers
- Electronic Planners
- Battery-Powered Equipment

Available in Green

- UTDFN-1X1-4L Package
- SC70-5 Package
- SOT-23-5 Package

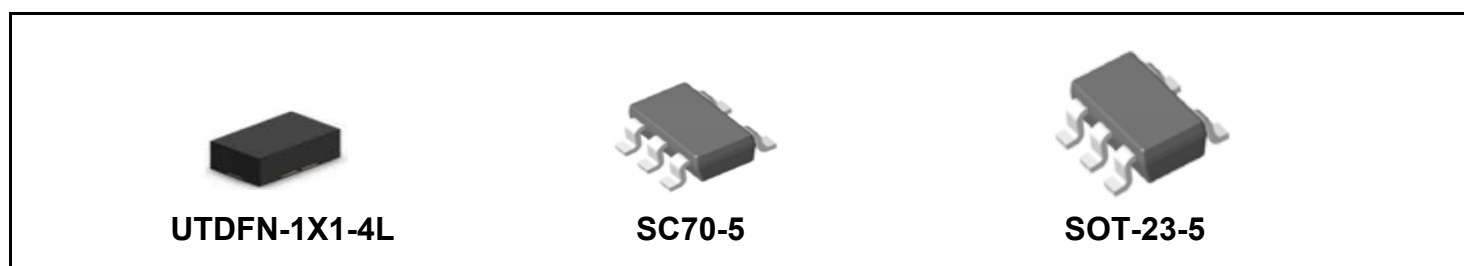
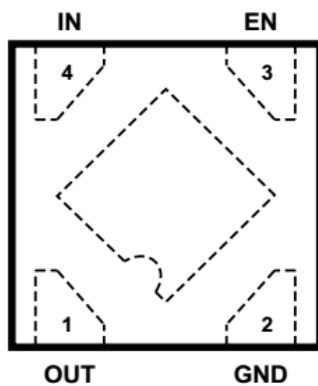

Figure 1. Package Type of SWLD2336

Pin Configuration

UTDFN-1X1-4L Package



SC70-5/SOT-23-5

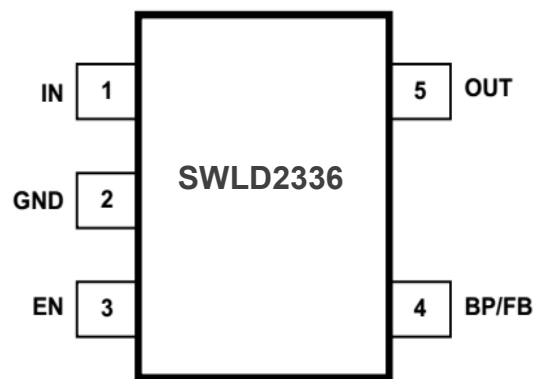
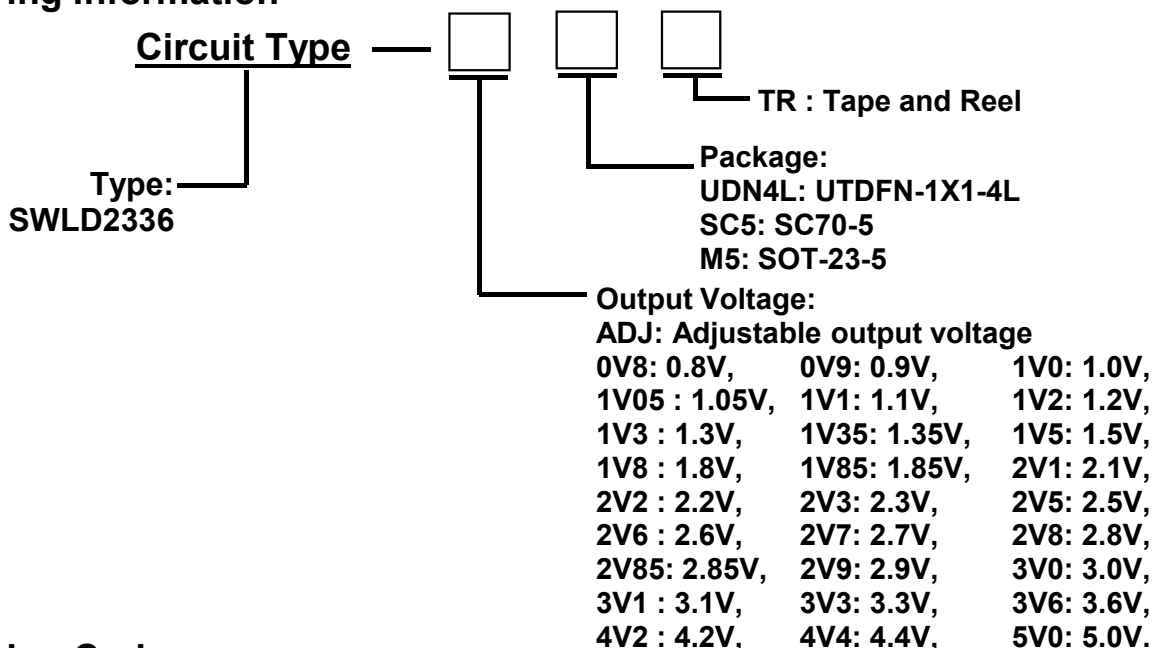

Figure 2. Pin Configuration of SWLD2336 (Top View)

Pin Function Table

UTDFN-1X1-4L	SC70-5/ SOT-23-5	NAME	Function
1	5	OUT	Regulator Output.
2	2	GND	Ground
3	3	EN	Enable Pin. This pin has an internal pull-down resistor. A logic low reduces the supply current to less than 1uA. Connect to IN for normal operation.
4	1	IN	Regulator Input. Supply voltage can range from 1.6V to 5.5V. Bypass with a 1uF capacitor to GND.
-	4	BP	Reference-Noise Bypass Pin (fixed voltage version only). Bypass with a low-leakage 0.01uF ceramic capacitor for reduced noise at the output. The capacitor is recommended to be placed very close to the pin for high PSSR.
		FB	Feedback Pin (adjustable voltage version only). This is used to set the output voltage of the device.
Exposed Pad	-	-	The exposed pad should be connected to a large ground plane to maximize thermal performance.

Ordering Information



Ordering Code

Part Number	V _{OUT} (V)	Marking ID <small>note1</small>	Temperature Range	Package	Package Type
SWLD2336-0V8UDN4LTR	0.8V	SF	-40°C to +85°C	UTDFN-1X1-4L	10000pcs/TR
SWLD2336-0V9UDN4LTR	0.9V	NE	-40°C to +85°C	UTDFN-1X1-4L	10000pcs/TR
SWLD2336-1V0UDN4LTR	1.0V	J3	-40°C to +85°C	UTDFN-1X1-4L	10000pcs/TR
SWLD2336-1V05UDN4LTR	1.05V	NF	-40°C to +85°C	UTDFN-1X1-4L	10000pcs/TR
SWLD2336-1V1UDN4LTR	1.1V	O0	-40°C to +85°C	UTDFN-1X1-4L	10000pcs/TR
SWLD2336-1V2UDN4LTR	1.2V	HE	-40°C to +85°C	UTDFN-1X1-4L	10000pcs/TR
SWLD2336-1V3UDN4LTR	1.3V	O1	-40°C to +85°C	UTDFN-1X1-4L	10000pcs/TR
SWLD2336-1V35UDN4LTR	1.35V	Z7	-40°C to +85°C	UTDFN-1X1-4L	10000pcs/TR
SWLD2336-1V5UDN4LTR	1.5V	HF	-40°C to +85°C	UTDFN-1X1-4L	10000pcs/TR
SWLD2336-1V8UDN4LTR	1.8V	I0	-40°C to +85°C	UTDFN-1X1-4L	10000pcs/TR
SWLD2336-1V85UDN4LTR	1.85V	O2	-40°C to +85°C	UTDFN-1X1-4L	10000pcs/TR
SWLD2336-2V1UDN4LTR	2.1V	O3	-40°C to +85°C	UTDFN-1X1-4L	10000pcs/TR
SWLD2336-2V2UDN4LTR	2.2V	O4	-40°C to +85°C	UTDFN-1X1-4L	10000pcs/TR
SWLD2336-2V3UDN4LTR	2.3V	SA	-40°C to +85°C	UTDFN-1X1-4L	10000pcs/TR
SWLD2336-2V5UDN4LTR	2.5V	O5	-40°C to +85°C	UTDFN-1X1-4L	10000pcs/TR
SWLD2336-2V6UDN4LTR	2.6V	N6	-40°C to +85°C	UTDFN-1X1-4L	10000pcs/TR
SWLD2336-2V7UDN4LTR	2.7V	O6	-40°C to +85°C	UTDFN-1X1-4L	10000pcs/TR
SWLD2336-2V8UDN4LTR	2.8V	I1	-40°C to +85°C	UTDFN-1X1-4L	10000pcs/TR
SWLD2336-2V85UDN4LTR	2.85V	O7	-40°C to +85°C	UTDFN-1X1-4L	10000pcs/TR
SWLD2336-2V9UDN4LTR	2.9V	O8	-40°C to +85°C	UTDFN-1X1-4L	10000pcs/TR
SWLD2336-3V0UDN4LTR	3.0V	I2	-40°C to +85°C	UTDFN-1X1-4L	10000pcs/TR
SWLD2336-3V3UDN4LTR	3.3V	I3	-40°C to +85°C	UTDFN-1X1-4L	10000pcs/TR

Ordering Code (Con.)

Part Number	V _{OUT} (V)	Marking ID <small>note1</small>	Temperature Range	Package	Package Type
SWLD2336-ADJSM5TR	ADJ	SQ7XX	-40°C to +85°C	SOT-23-5	3000pcs/TR
SWLD2336-0V8M5TR	0.8V	SS7XX	-40°C to +85°C	SOT-23-5	3000pcs/TR
SWLD2336-0V9M5TR	0.9V	SP0XX	-40°C to +85°C	SOT-23-5	3000pcs/TR
SWLD2336-1V0M5TR	1.0V	SP1XX	-40°C to +85°C	SOT-23-5	3000pcs/TR
SWLD2336-1V05M5TR	1.05V	SP2XX	-40°C to +85°C	SOT-23-5	3000pcs/TR
SWLD2336-1V1M5TR	1.1V	SP3XX	-40°C to +85°C	SOT-23-5	3000pcs/TR
SWLD2336-1V2M5TR	1.2V	SP4XX	-40°C to +85°C	SOT-23-5	3000pcs/TR
SWLD2336-1V3M5TR	1.3V	SP5XX	-40°C to +85°C	SOT-23-5	3000pcs/TR
SWLD2336-1V5M5TR	1.5V	SP6XX	-40°C to +85°C	SOT-23-5	3000pcs/TR
SWLD2336-1V8M5TR	1.8V	SP7XX	-40°C to +85°C	SOT-23-5	3000pcs/TR
SWLD2336-1V85M5TR	1.85V	SP8XX	-40°C to +85°C	SOT-23-5	3000pcs/TR
SWLD2336-2V1M5TR	2.1V	SP9XX	-40°C to +85°C	SOT-23-5	3000pcs/TR
SWLD2336-2V2M5TR	2.2V	SPAXX	-40°C to +85°C	SOT-23-5	3000pcs/TR
SWLD2336-2V3M5TR	2.3V	SS9XX	-40°C to +85°C	SOT-23-5	3000pcs/TR
SWLD2336-2V5M5TR	2.5V	SPBXX	-40°C to +85°C	SOT-23-5	3000pcs/TR
SWLD2336-2V6M5TR	2.6V	SN5XX	-40°C to +85°C	SOT-23-5	3000pcs/TR
SWLD2336-2V7M5TR	2.7V	SPCXX	-40°C to +85°C	SOT-23-5	3000pcs/TR
SWLD2336-2V8M5TR	2.8V	YJ28XX	-40°C to +85°C	SOT-23-5	3000pcs/TR
SWLD2336-2V85M5TR	2.85V	SPEXX	-40°C to +85°C	SOT-23-5	3000pcs/TR
SWLD2336-2V9M5TR	2.9V	SPFXX	-40°C to +85°C	SOT-23-5	3000pcs/TR
SWLD2336-3V0M5TR	3.0V	SQ0XX	-40°C to +85°C	SOT-23-5	3000pcs/TR
SWLD2336-3V1M5TR	3.1V	SQ1XX	-40°C to +85°C	SOT-23-5	3000pcs/TR
SWLD2336-3V3M5TR	3.3V	GCGXX	-40°C to +85°C	SOT-23-5	3000pcs/TR
SWLD2336-3V6M5TR	3.6V	SQ3XX	-40°C to +85°C	SOT-23-5	3000pcs/TR
SWLD2336-4V2M5TR	4.2V	SQ4XX	-40°C to +85°C	SOT-23-5	3000pcs/TR
SWLD2336-4V4M5TR	4.4V	SQ5XX	-40°C to +85°C	SOT-23-5	3000pcs/TR
SWLD2336-5V0M5TR	5.0V	SQ6XX	-40°C to +85°C	SOT-23-5	3000pcs/TR
SWLD2336-ADJSC5TR	ADJ	SRFXX	-40°C to +85°C	SC70-5	3000pcs/TR
SWLD2336-0V8SC5TR	0.8V	SSBXX	-40°C to +85°C	SC70-5	3000pcs/TR
SWLD2336-0V9SC5TR	0.9V	SQ8XX	-40°C to +85°C	SC70-5	3000pcs/TR
SWLD2336-1V0SC5TR	1.0V	SQ9XX	-40°C to +85°C	SC70-5	3000pcs/TR
SWLD2336-1V05SC5TR	1.05V	SQAXX	-40°C to +85°C	SC70-5	3000pcs/TR
SWLD2336-1V1SC5TR	1.1V	SQBXX	-40°C to +85°C	SC70-5	3000pcs/TR
SWLD2336-1V2SC5TR	1.2V	SQCXX	-40°C to +85°C	SC70-5	3000pcs/TR
SWLD2336-1V3SC5TR	1.3V	SQDXX	-40°C to +85°C	SC70-5	3000pcs/TR
SWLD2336-1V5SC5TR	1.5V	SQEXX	-40°C to +85°C	SC70-5	3000pcs/TR

Absolute Maximum Ratings ^{Note 1}

Parameter	Symbol	Value	Unit	
Supply Voltage, IN to GND	V _{IN}	-0.3 to 6	V	
Output Short-Circuit Duration	V _{OscD}	Infinite	-	
Supply Voltage from EN to GND	V _{EN}	-0.3 to 6	V	
Difference Voltage from OUT, BP/FB to GND	V _{DF}	-0.3 to (V _{IN} +0.3V)	V	
Power Dissipation at TA=25°C	UTDFN-1X1-4L	400	mW	
	SC70-5	340		
	SOT-23-5	390		
Thermal Resistance at TA=+25°C	UTDFN-1X1-4L	θ _{JA}	280	'C/W
	SC70-5	θ _{JA}	330	'C/W
	SOT-23-5	θ _{JA}	285	'C/W
Storage Temperature Range	T _{STORAGE}	-65 to +150	'C	
Junction Temperature	T _J	+150	'C	
Lead Temperature (Soldering, 10s)	T _{LEAD}	+260	'C	
Human Body Model ESD Protection	ESD HBM	4000	V	
Machine Model ESD Protection	ESD MM	400	V	

Note 1: Stresses above those listed under "Maximum Ratings" may cause permanent damage to the device.

This is a stress rating only and functional operation of the device at those or any other conditions above those indicated in the operational listings of this specification is not implied. Exposure to maximum rating conditions for extended periods may affect device reliability.

Recommended Operating Conditions

Parameter	Symbol	Value	Unit
Operating Voltage Range	V _{IN}	1.6V to 5.5V	V
Operating Temperature Range	T _{OPERATING}	-40 to 85	'C

Electrical Characteristics ($V_{IN}=V_{OUT(NOMINAL)}+0.5V^{note1}$, Full=-40°C to 85°C, unless otherwise noted.)

Parameter	Symbol	Conditions	Min	Type	Max	Unit	
Input Voltage	V_{IN}	$V_{CM}=0.3V$	1.6	-	5.5	V	
Output Voltage Accuracy ^{note1}		$I_{OUT}=0.1mA$	-2.5	-	2.5	%	
Feedback Voltage	V_{FB}	$I_{OUT}=0.1mA$, SWLD2336-ADJ	0.78	0.80	0.82	V	
Maximum Output Current ^{note1}	I_{OUT}		300	-	-	mA	
Current Limit ^{note1}	I_{LIM}		360	560	-	mA	
Supply Pin Current	I_Q	No load, $EN=V_{IN}$	-	20	26	uA	
Dropout Voltage ^{note2}	V_{DROP}	$I_{OUT}=300mA$	$V_{OUT}=0.8V$	-	940	1200	mV
			$V_{OUT}=0.9V$	-	840	1100	
			$1.0V \leq V_{OUT} < 1.1V$	-	780	1000	
			$1.1V \leq V_{OUT} < 1.2V$	-	680	900	
			$1.2V \leq V_{OUT} < 1.5V$	-	590	800	
			$1.5V \leq V_{OUT} < 1.8V$	-	420	550	
			$1.8V \leq V_{OUT} < 2.1V$	-	320	420	
			$2.1V \leq V_{OUT} < 2.5V$	-	260	340	
			$2.5V \leq V_{OUT} < 3.0V$	-	215	280	
			$3.0V \leq V_{OUT} < 3.6V$	-	190	250	
$3.6V \leq V_{OUT} < 5.0V$	-	165	210				
Line Regulation ^{note1}	ΔV_{LNR}	$V_{IN}=1.6V$ to $5.5V$, $I_{OUT}=1mA$	$1.8V \leq V_{OUT} < 3.3V$	-	0.01	0.06	% / V
			$V_{OUT} < 1.8V$ or $V_{OUT} \geq 3.3V$	-	0.01	0.1	
Load Regulation	ΔV_{OUT}	$I_{OUT}=0.1mA$ to $300mA$	-	12	40	mV	
		$I_{OUT}=0.1mA$ to $300mA$, SWLD2336-ADJ	-	0.5	10		
Short Current Limit	I_{SHORT}	$V_{OUT} = 0V$	-	200	-	mA	
Power Supply Rejection Ratio	PSRR	CBP=0uF, $I_{LOAD}=30mA$ COUT=1uF, $V_{IN}=V_{OUT}+1V$, $\Delta V_{RIPPLE}=0.2VP-P$	f=217Hz	-	80	-	dB
			f=1KHz	-	75	-	
		CBP=0.01uF, $I_{LOAD}=30mA$ COUT=1uF, $V_{IN}=V_{OUT}+1V$, $\Delta V_{RIPPLE}=0.2VP-P$	f=217Hz	-	82	-	
			f=1KHz	-	70	-	
Output Voltage Noise	e_n	CBP=0uF, f=10Hz to 100KHz, COUT=1uF, $V_{OUT}=1.8V$	$I_{OUT}=0mA$	-	100	-	uVRMS
			$I_{OUT}=30mA$	-	200	-	
		CBP=0.01uF, f=10Hz to 100KHz, COUT=1uF, $V_{OUT}=1.8V$	$I_{OUT}=0mA$	-	30	-	
			$I_{OUT}=30mA$	-	75	-	
Output Voltage Temperature Coefficient ^{note3}	ΔV_{OVTC}	$I_{OUT} = 0.1mA$	-	30	-	ppm/°C	
EN Input Threshold	V_{IH}	$V_{IN}=1.6V$ to $5.5V$	1.5	-	-	V	
	V_{IL}		-	-	0.4		
EN Input Bias Current	I_{BH}	$V_{EN}=5.5V$	-	0.8	2	uA	
	I_{BL}	$V_{EN}=0V$	-	0.01	1		
Shutdown Supply Current	I_{SHDN}	$V_{EN}=0V$	-	0.01	1	uA	
Start-Up Time ^{note4}	tSTR	COUT=1uF, No Load	-	30	-	us	
RON of Discharge MOSFET	R_{Ω}	$V_{IN}=4.0V$, $V_{EN}=0V$	-	50	-	Ω	
Thermal Shutdown Temperature	TSHDN		-	140	-	°C	
Thermal Shutdown Hysteresis	ΔT_{SHDN}		-	15	-	°C	

note 1. Max Output Current is affected by the PCB layout, attention should be paid to the dropout voltage when $V_{IN} < V_{OUT} + V_{DROP}$

2. The dropout voltage is defined as $V_{IN} - V_{OUT}$, when V_{OUT} is 100mV below the value of V_{OUT} for $V_{IN} = V_{OUT} + 0.5V$ or $2.5V$.

3. Output voltage temperature coefficient is defined as the worst-case voltage change divided by the total temperature range.

4. Time needed for V_{OUT} to reach 90% of final value.

Typical Performance Characteristics (Unless Otherwise Specified.)

($V_{EN}=V_{IN}$, $C_{IN}=1\mu F$, $C_{OUT}=1\mu F$, $C_{BP}=0\mu F$, $T_A=25^\circ C$ unless otherwise noted.)

Turn On Speed with EN Pin

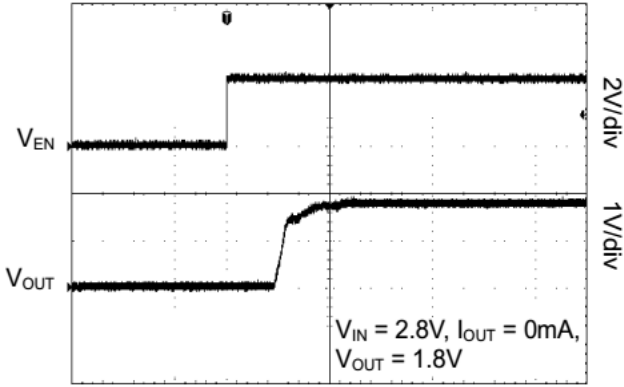

Time (20µs/div)

Turn On Speed with EN Pin

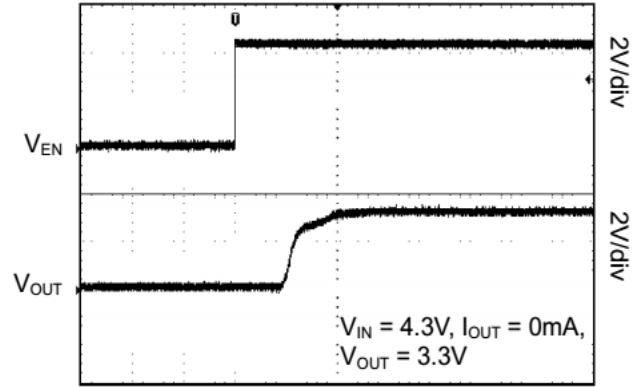

Time (20µs/div)

Turn Off Speed with EN Pin

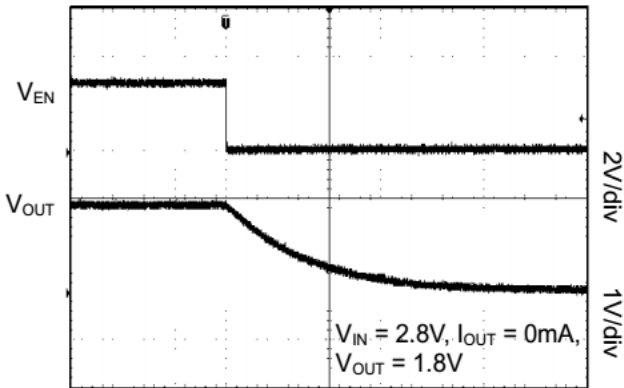

Time (40µs/div)

Turn Off Speed with EN Pin

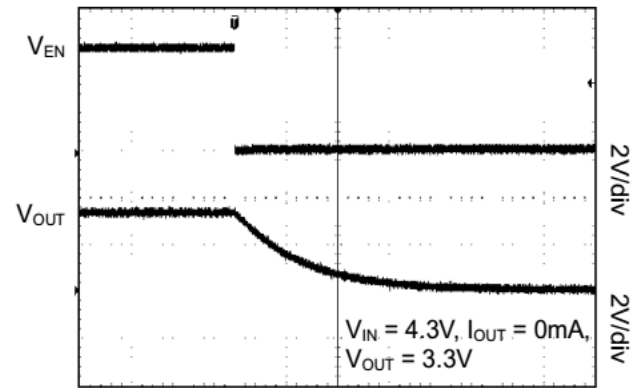

Time (40µs/div)

Line Transient Response

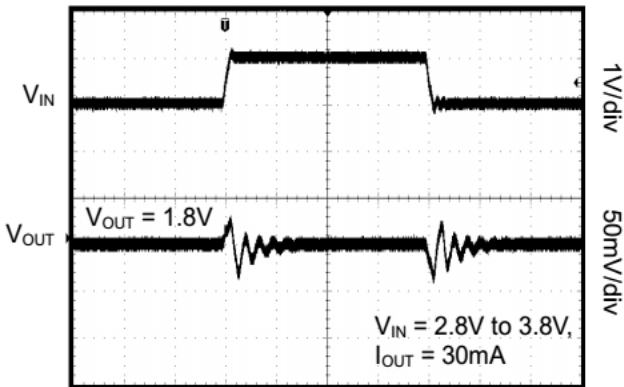

Time (40µs/div)

Line Transient Response

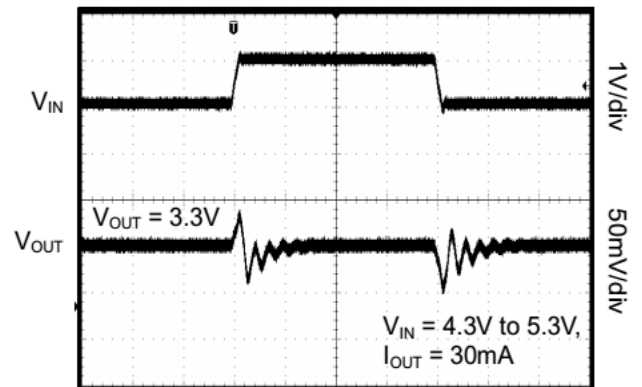

Time (40µs/div)

Typical Performance Characteristics (Unless Otherwise Specified.)

($V_{EN}=V_{IN}$, $C_{IN}=1\mu F$, $C_{OUT}=1\mu F$, $C_{BP}=0\mu F$, $T_A=25^\circ C$ unless otherwise noted.)

Load Transient Response

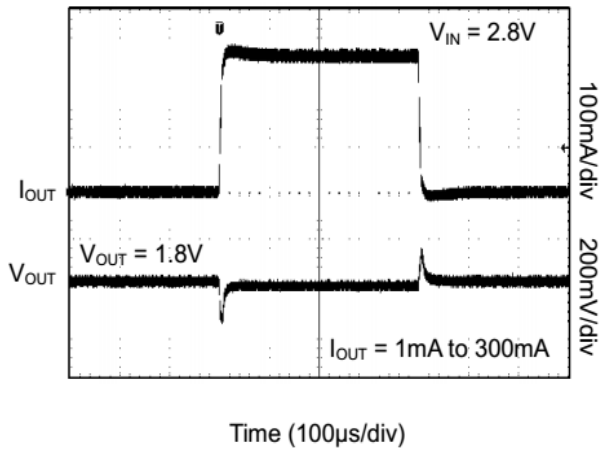

Load Transient Response

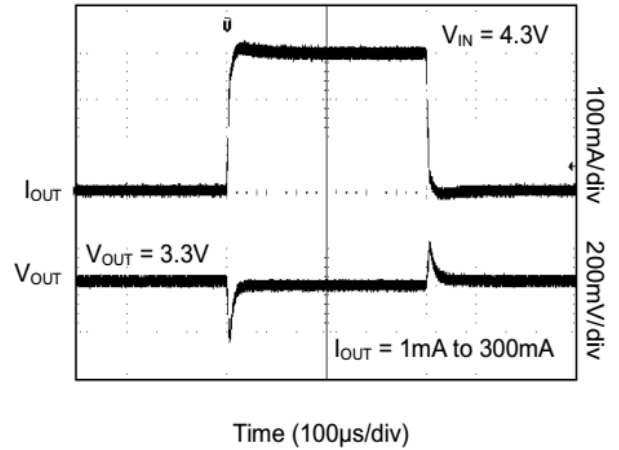

Load Transient Response

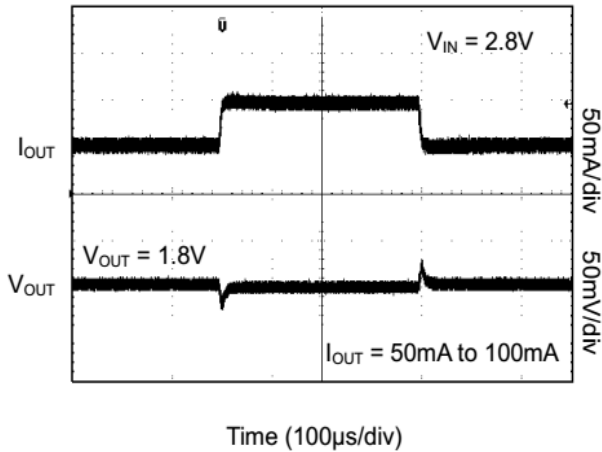

Load Transient Response

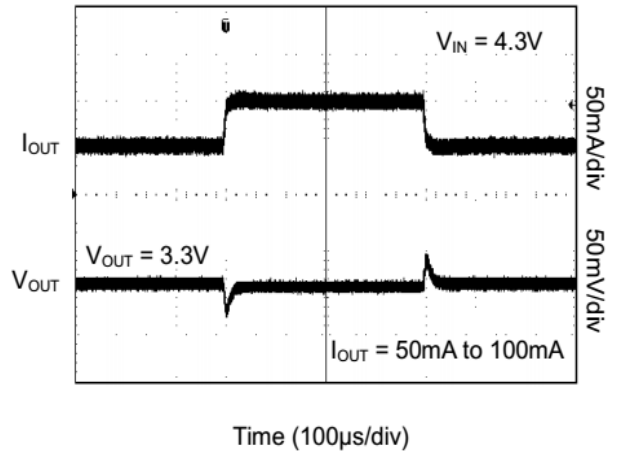

Power Supply Rejection Ratio vs. Frequency

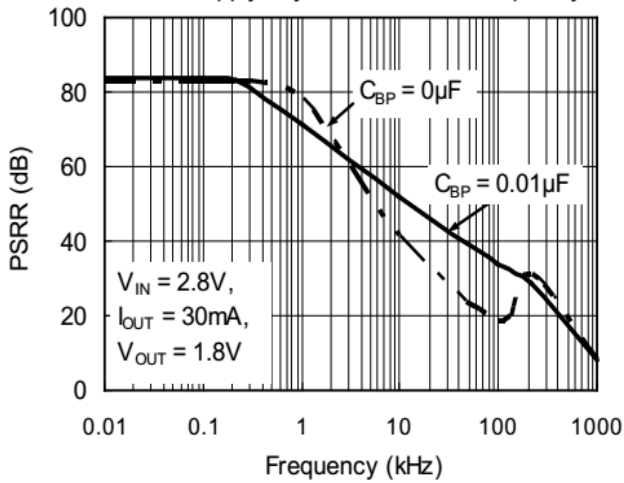

Power Supply Rejection Ratio vs. Frequency

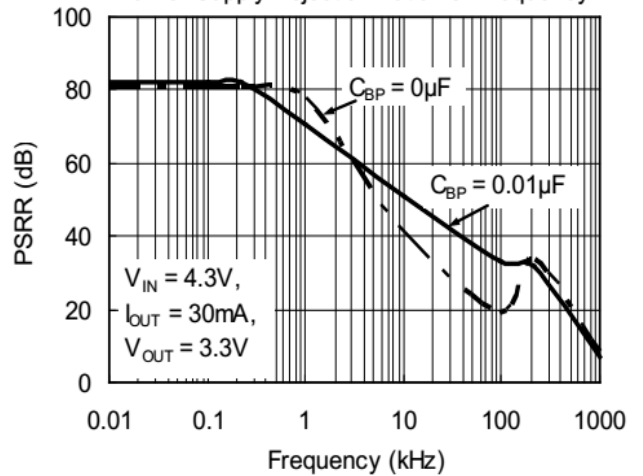

Typical Performance Characteristics (Unless Otherwise Specified.)

($V_{EN}=V_{IN}$, $C_{IN}=1\mu F$, $C_{OUT}=1\mu F$, $C_{BP}=0\mu F$, $T_A=25^\circ C$ unless otherwise noted.)

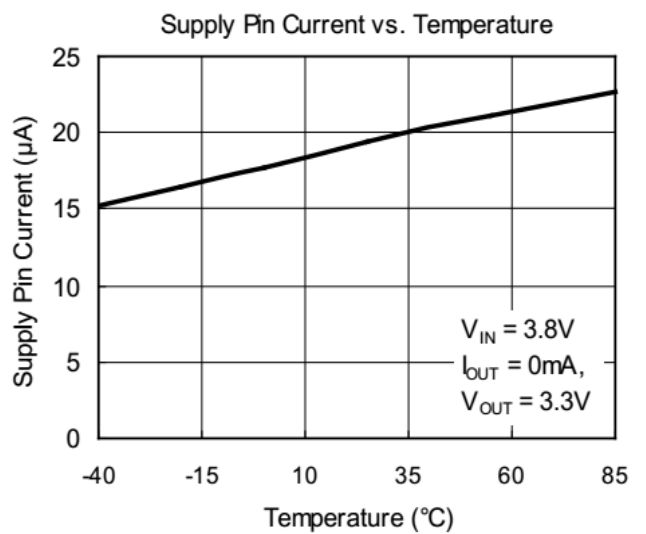
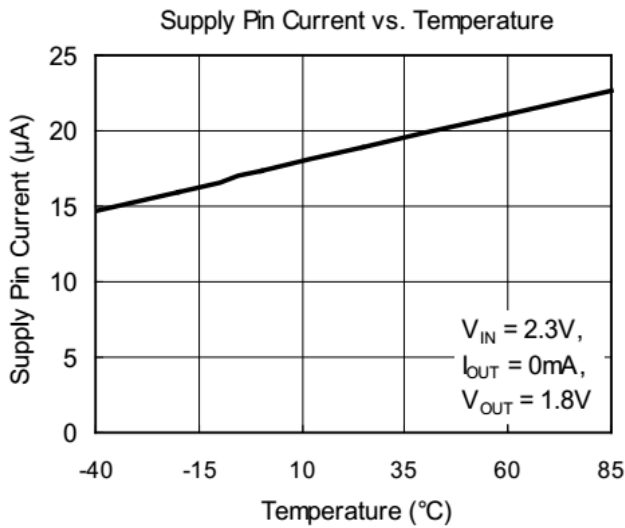
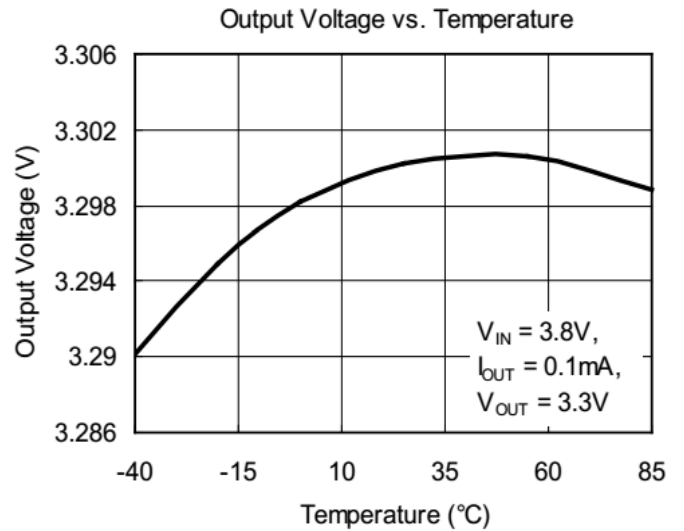
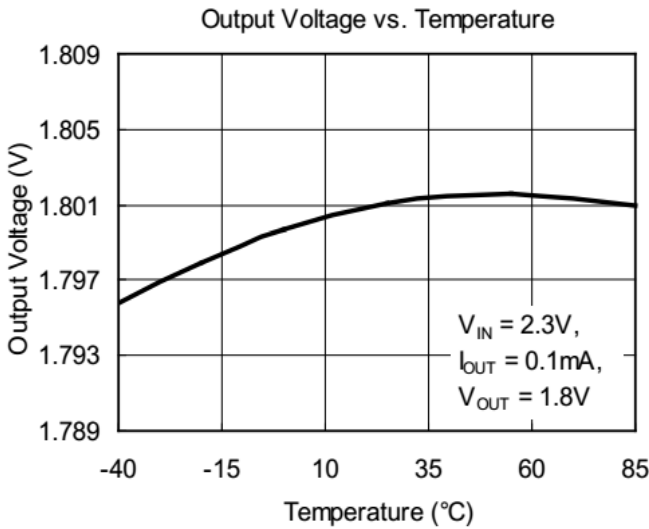
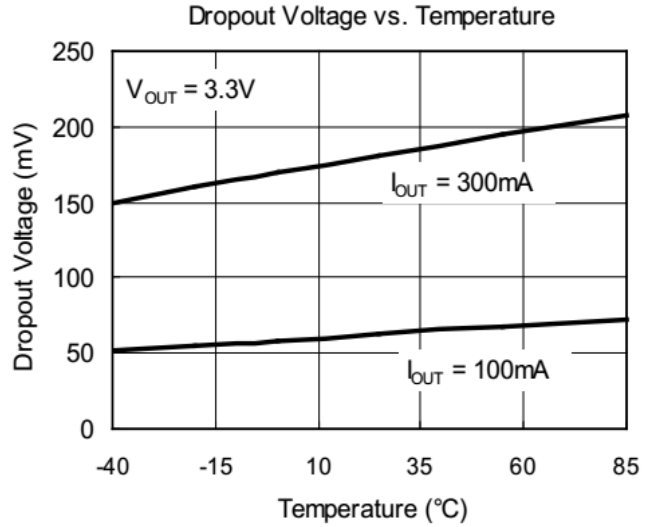
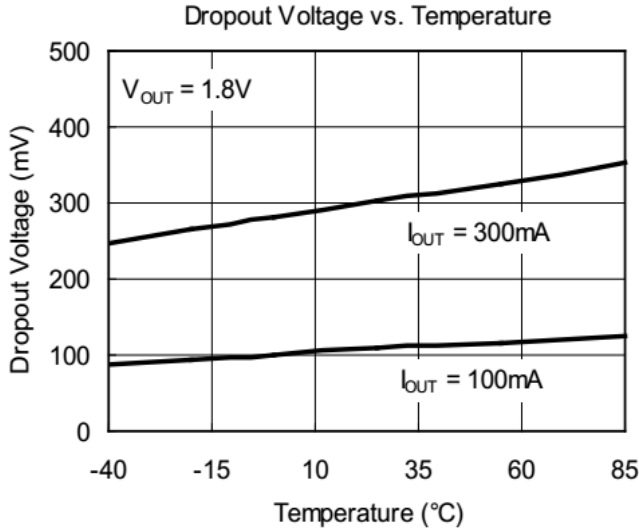

Typical Performance Characteristics (Unless Otherwise Specified.)

($V_{EN}=V_{IN}$, $C_{IN}=1\mu F$, $C_{OUT}=1\mu F$, $C_{BP}=0\mu F$, $T_A=25^\circ C$ unless otherwise noted.)

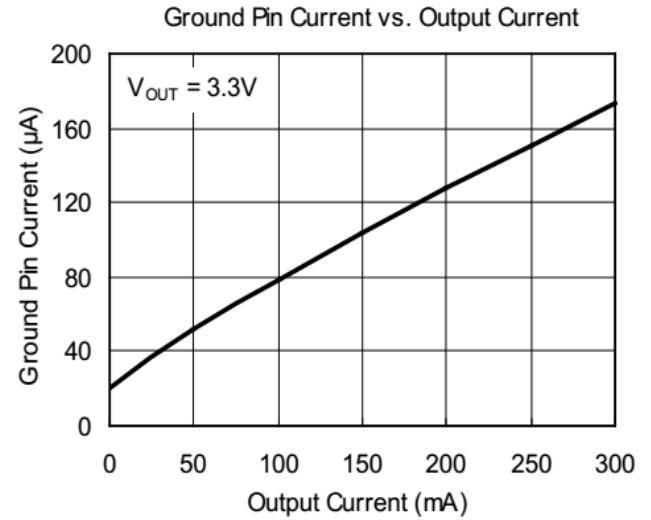
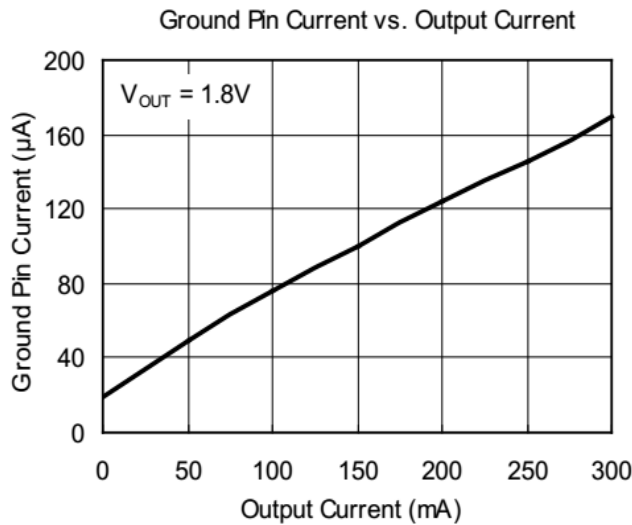
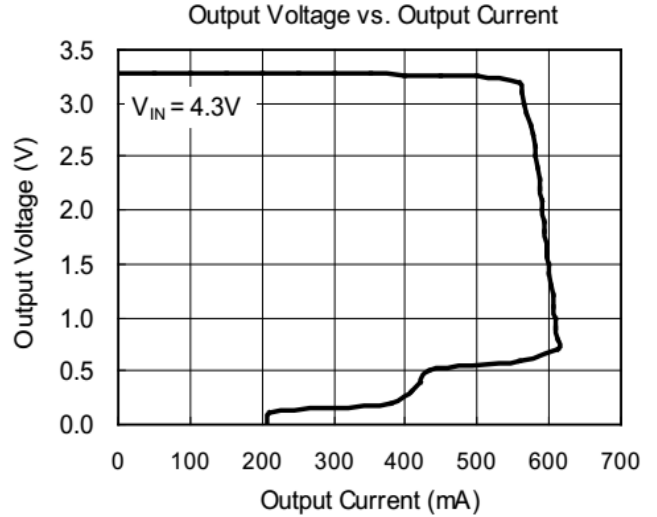
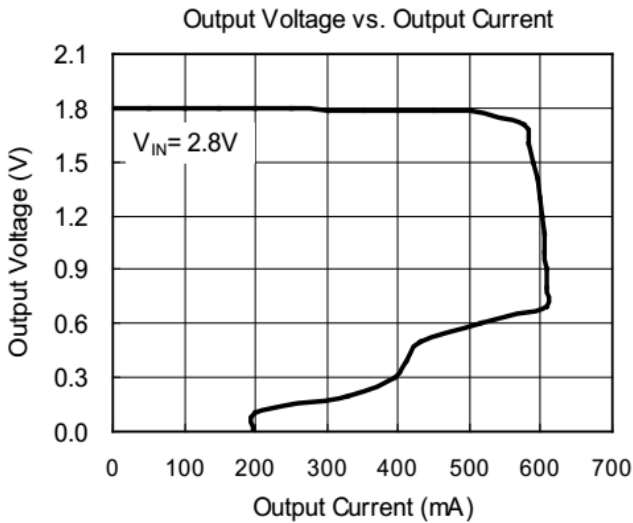
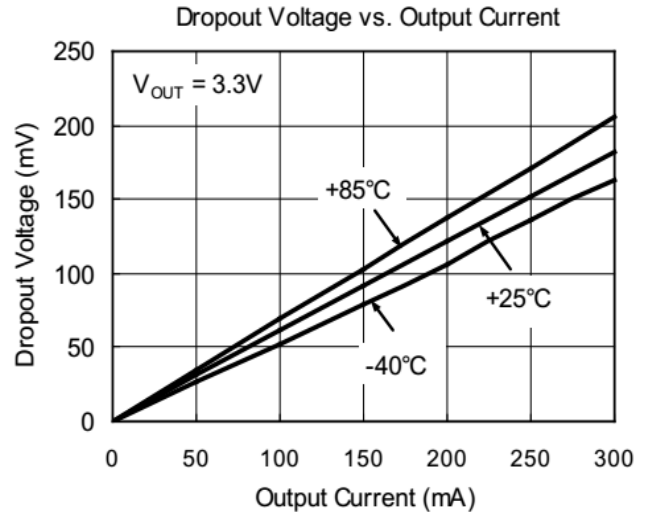
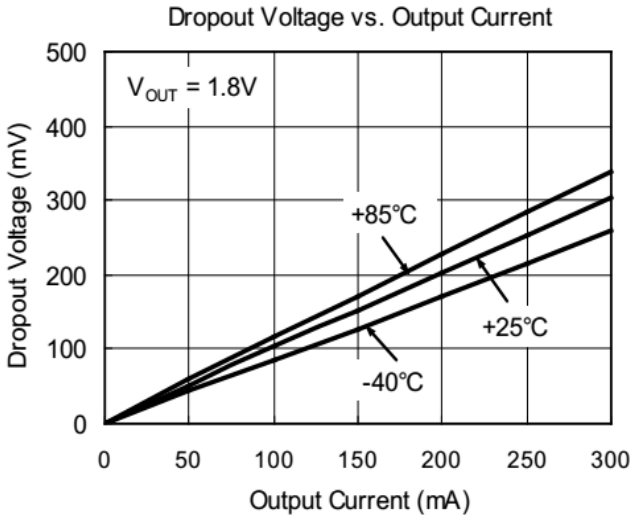

Typical Performance Characteristics (Unless Otherwise Specified.)

($V_{EN}=V_{IN}$, $C_{IN}=1\mu F$, $C_{OUT}=1\mu F$, $C_{BP}=0\mu F$, $T_A=25^\circ C$ unless otherwise noted.)

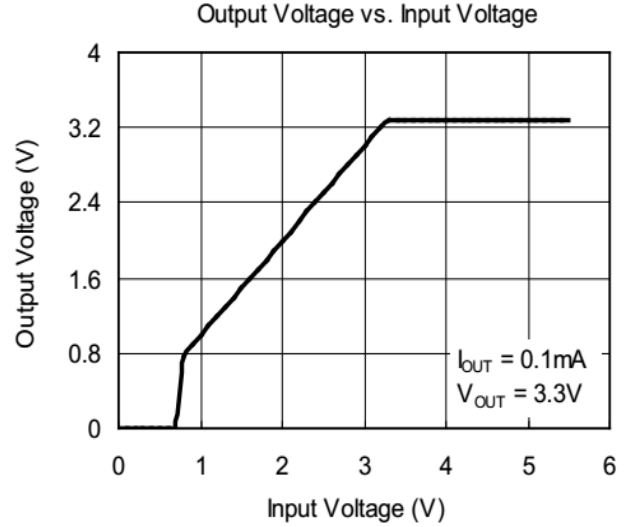
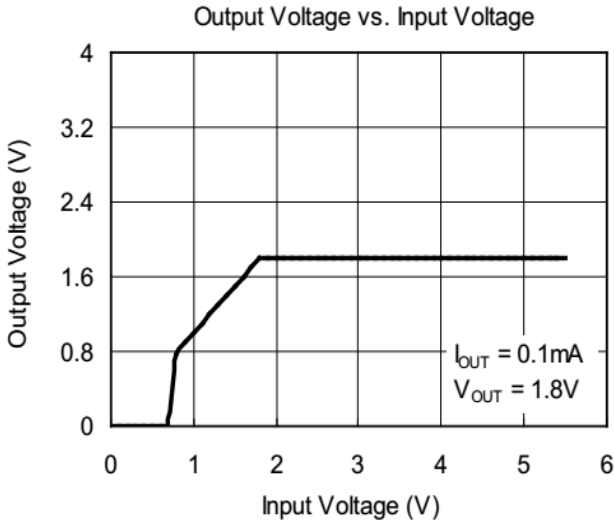

Typical Application Circuit

- The Fixed Output Voltage of typical application circuit

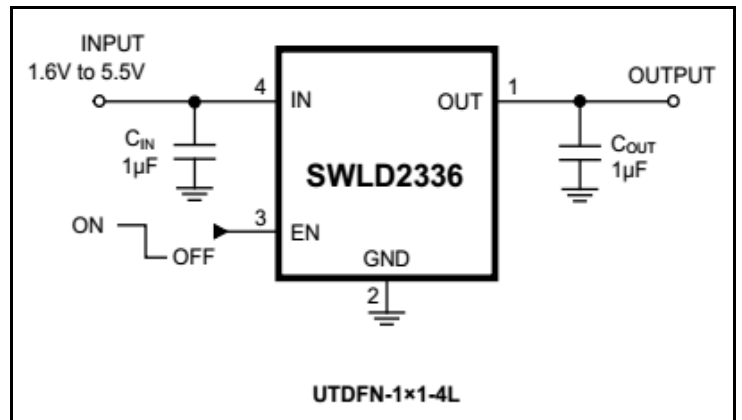
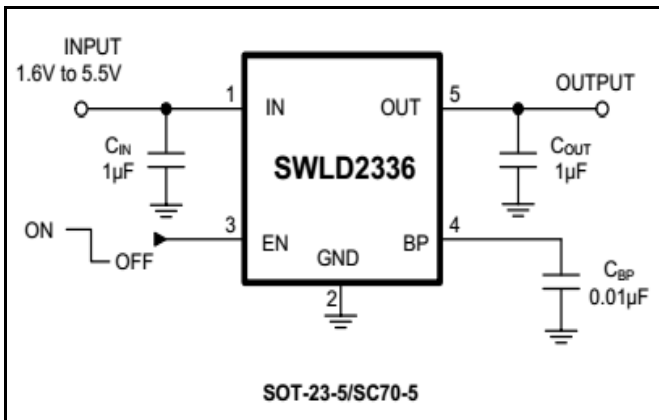

- The adjustable Output Voltage of typical application circuit

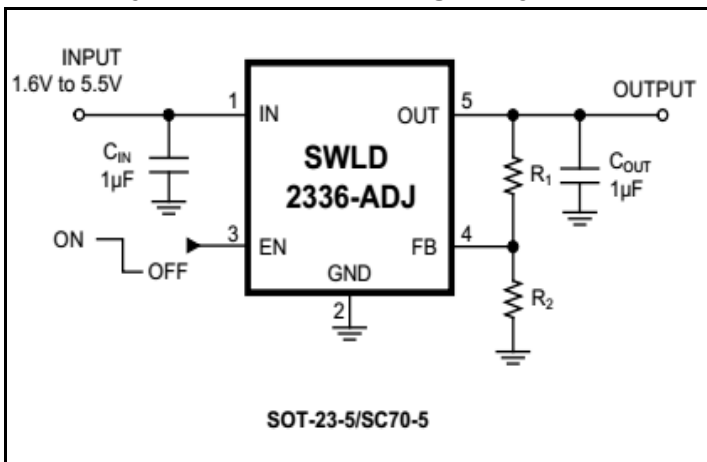

Note: Choose $R_2=160K\Omega$ to maintain a 5uA minimum load.

Calculate the value for R_1 using the following equation:

$$R_1 = R_2 \times \left(\frac{V_{OUT}}{0.8V} - 1 \right)$$

APPLICATION NOTE

When LDO is used in handheld products, attention must be paid to voltage spikes which could damage SWLD2336. In such applications, voltage spikes will be generated at charger interface and VBUS pin of USB interface when charger adapters and USB equipments are hot-plugged. Besides this, handheld products will be tested on the production line without battery. Test engineer will apply power from the connector pin which connects with positive pole of the battery. When external power supply is turned on suddenly, the voltage spikes will be generated at the battery connector. The voltage spikes will be high, and it always exceeds the absolute maximum input voltage (6.0V) of LDO. In order to get robust design, design engineer needs to clear up this voltage spike. Zener diode is a cheap and effective solution to eliminate such voltage spike. For example, SZD50BJ5V6 is a 5.6V small package Zener diode which can be used to remove voltage spikes in cell phone designs. The schematic is shown below.

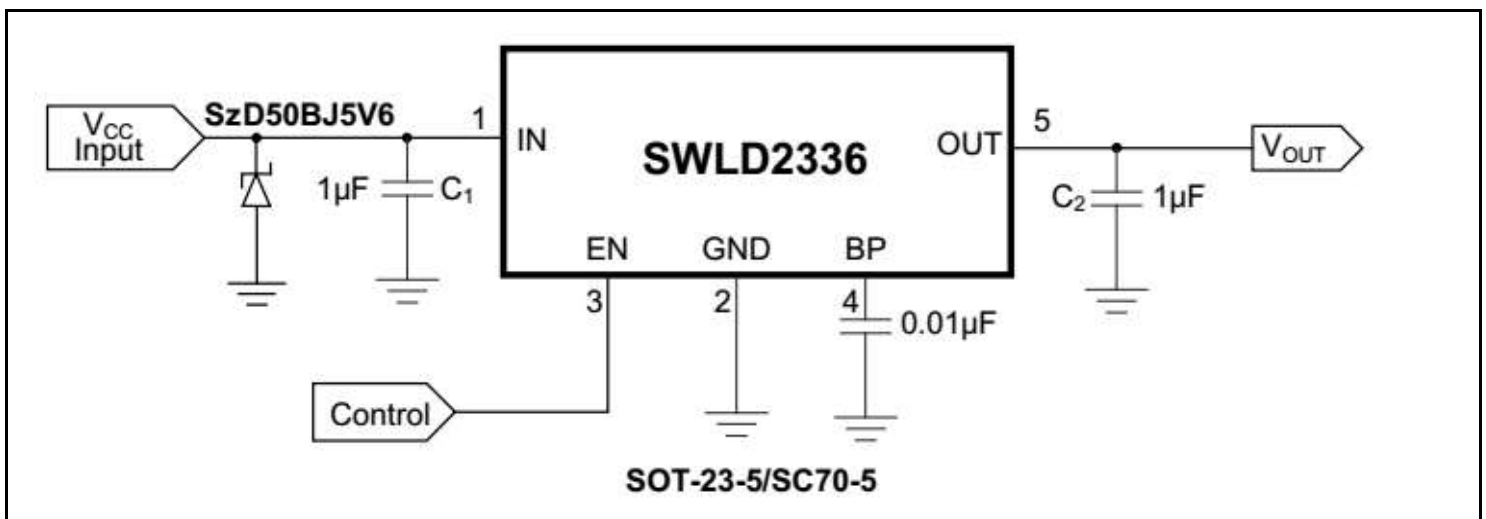
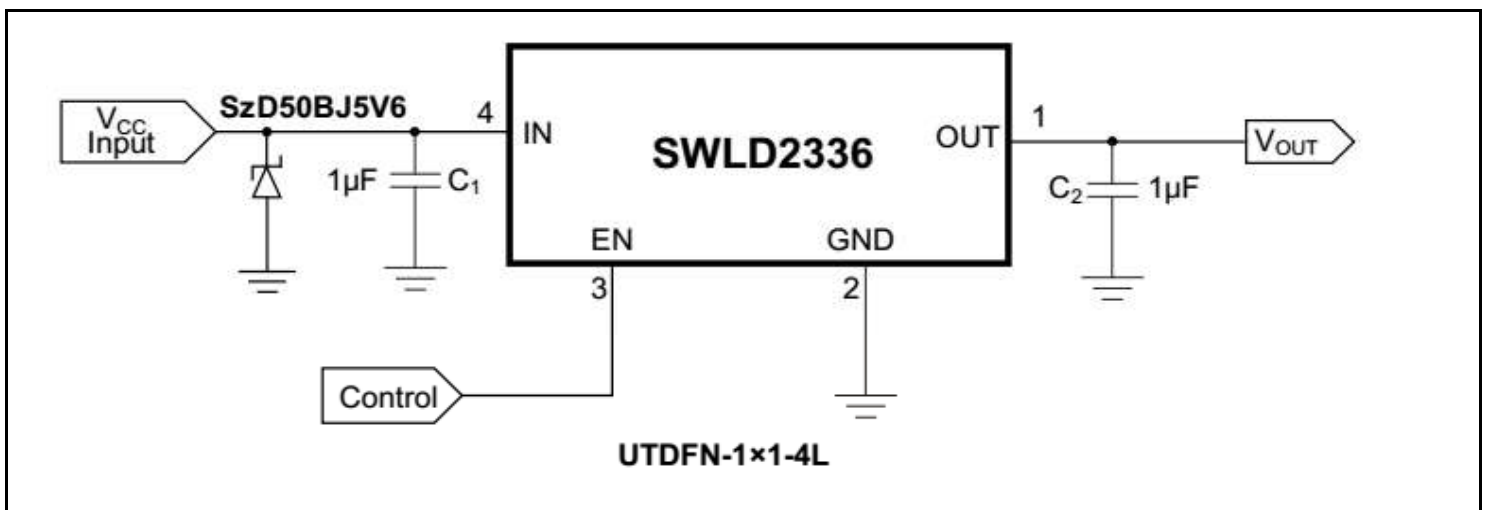

Mechanical Dimensions

PKG : UTDFN-1X1-4L (UDN4L)

Unit: mm (inch)

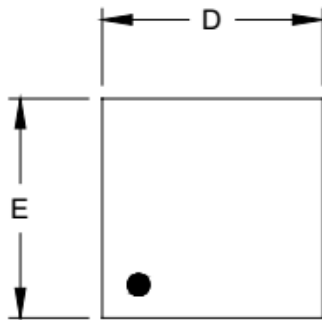

TOP VIEW

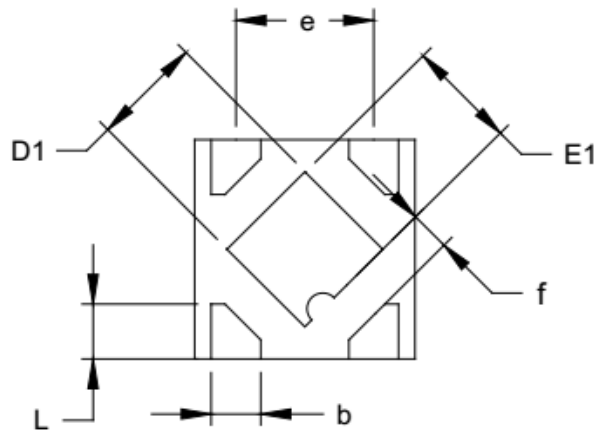

BOTTOM VIEW

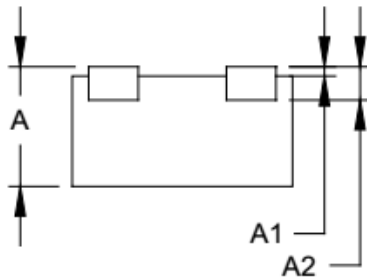

SIDE VIEW

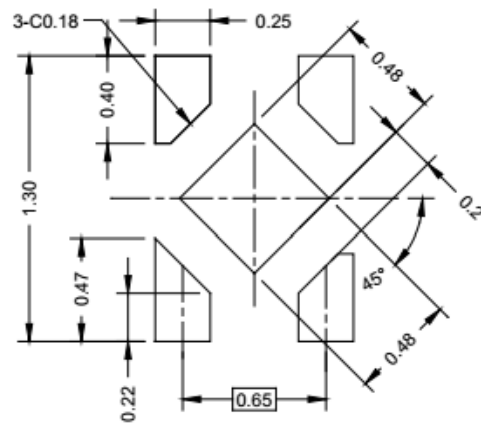

RECOMMENDED LAND PATTERN (Unit: mm)

Symbol	Dimensions In Millimeters		
	MIN	MOD	MAX
A	0.500	0.550	0.600
A1	0.000		0.050
A2	0.152 REF		
D	0.950	1.000	1.050
D1	0.450	0.500	0.550
E	0.950	1.000	1.050
E1	0.450	0.500	0.550
b	0.175	0.225	0.275
e	0.625 BSC		
f	0.195 REF		
L	0.200	0.250	0.300

Mechanical Dimensions (Con.)

PKG : SC70-5 (SC5)

Unit: mm (inch)

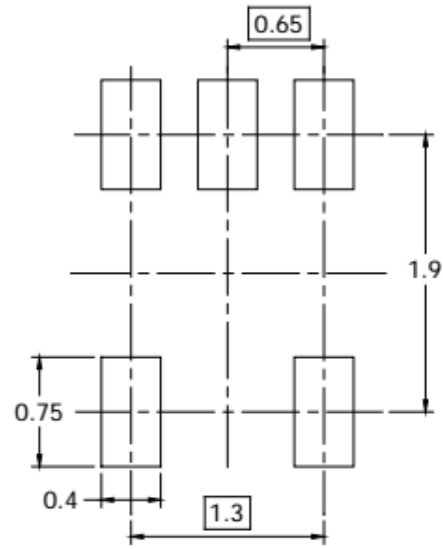
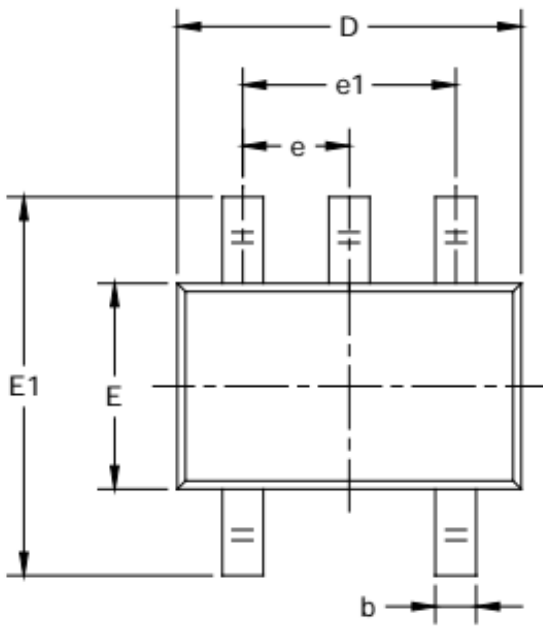

RECOMMENDED LAND PATTERN (Unit: mm)

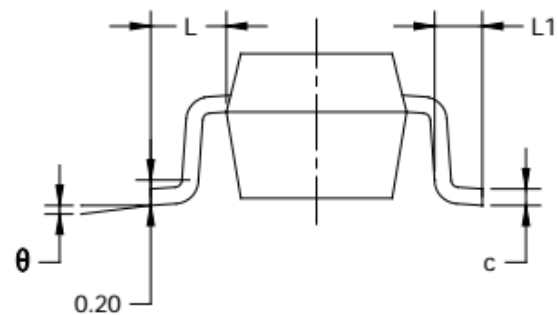
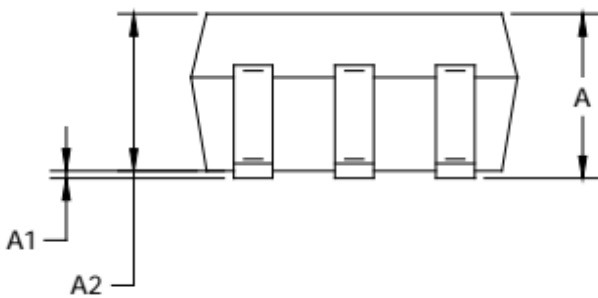

Symbol	Dimensions In Millimeters		Dimensions In Inches	
	MIN	MAX	MIN	MAX
A	0.900	1.100	0.035	0.043
A1	0.000	0.100	0.000	0.004
A2	0.900	1.000	0.035	0.039
b	0.150	0.350	0.006	0.014
c	0.080	0.150	0.003	0.006
D	2.000	2.200	0.079	0.087
E	1.150	1.350	0.045	0.053
E1	2.150	2.450	0.085	0.096
e	0.65 TYP		0.026 TYP	
e1	1.300 BSC		0.051 BSC	
L	0.525 REF		0.021 REF	
L1	0.260	0.460	0.010	0.018
θ	0°	8°	0°	8°

Mechanical Dimensions(Con.)

PKG:SOT-23-5 (M5)

Unit: mm (inch)

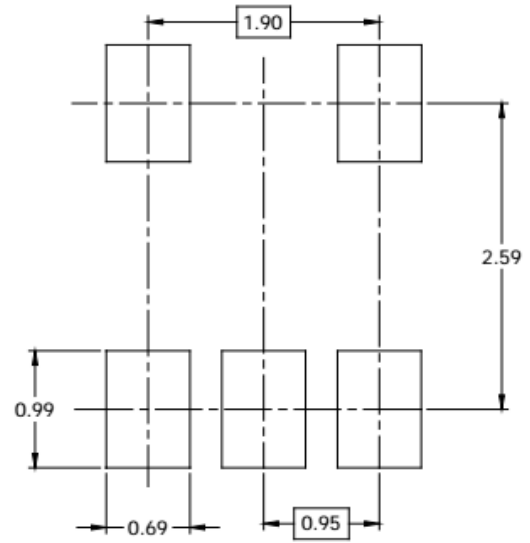
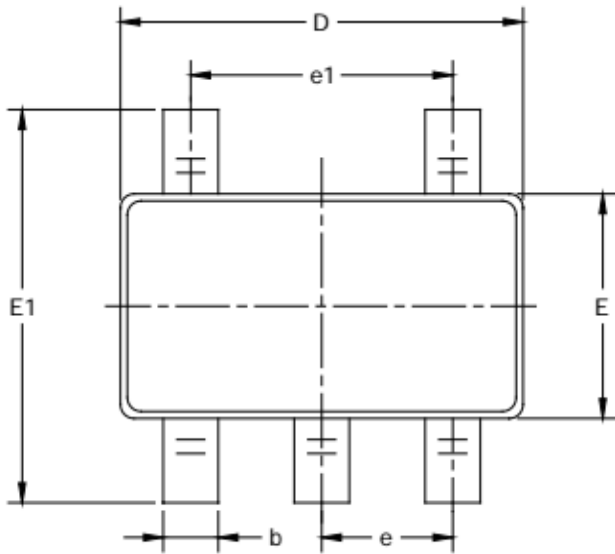

RECOMMENDED LAND PATTERN (Unit: mm)

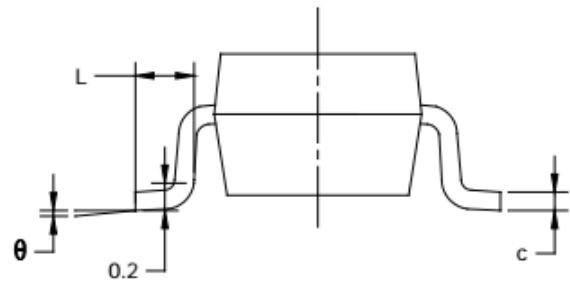
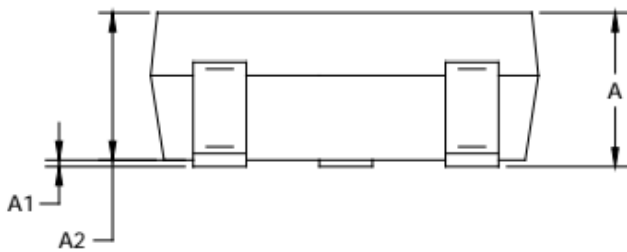

Symbol	Dimensions In Millimeters		Dimensions In Inches	
	MIN	MAX	MIN	MAX
A	1.050	1.250	0.041	0.049
A1	0.000	0.100	0.000	0.004
A2	1.050	1.150	0.041	0.045
b	0.300	0.500	0.012	0.020
c	0.100	0.200	0.004	0.008
D	2.820	3.020	0.111	0.119
E	1.500	1.700	0.059	0.067
E1	2.650	2.950	0.104	0.116
e	0.950 BSC		0.037 BSC	
e1	1.900 BSC		0.075 BSC	
L	0.300	0.600	0.012	0.024
θ	0°	8°	0°	8°